

B AC Motors

S.C. Reversible Motor 40W (□90mm)

40W

Speed Control Reversible Motor 40W(□90mm)

Motor 사양

Model 9SRDG*-40□: Gear Type Shaft 9SRDD*-40: D-Cut Type Shaft 9SRDK*-40: Key Type Shaft	Output W	Voltage V	Frequency Hz	Poles	Duty	Speed Range r/min	Starting Torque		Permissible Torque				Capacitor μF / VAC
									1200r/min		90r/min		
							kgfcm	N.m	kgfcm	N.m	kgfcm	N.m	
9SRDG1(A)-40□	40	1φ 110	60	4	30min.	90-1700	3.40	0.340	3.00	0.300	0.85	0.085	16.0 / 250
9SRDG2(D)-40□	40	1φ 220	60	4	30min.	90-1700	3.30	0.330	3.00	0.300	0.85	0.085	4.0 / 450
9SRDGE-40□	40	1φ 220	50	4	30min.	90-1400	3.00	0.300	2.60	0.260	0.80	0.080	4.0 / 450
		1φ 240					3.30	0.330	3.20	0.320	0.90	0.090	

- 1) 모터 모델명 * 자리에는 전압코드가, □ 안에는 부착되는 감속기의 모델 타입명이 들어갑니다.
- 2) 전압코드 A, D, E는 TP(Thermal Protector) 부착 사양입니다.
- 3) Gear Type Shaft는 감속기 부착용이며 D-Cut & Key Type Shaft는 모터 단독 사용시의 출력축 입니다.

감속기 부착 시 최대허용토크

Motor Model	Gear box Model	회전 속도 r/min	전압 V	주파수 Hz	감속비	2	3	3.6	5	6	7.5	9	10	12.5	15	18	20	25	30	36	40	50	60	75	90	100	120	150	180	200			
9SRDG*-40G	9GBK □ BMH	1200	110	60	kgfcm	4.9	7.3	8.7	12.2	14.6	18.2	21.9	24.3	30.4	36.5	43.7	43.8	54.8	65.7	78.8	87.6	99.0	100.0	100.0	100.0	100.0	100.0	100.0	100.0	100.0	100.0		
					N.m	0.48	0.71	0.86	1.19	1.43	1.79	2.14	2.38	2.98	3.57	4.29	4.29	5.37	6.44	7.73	8.58	9.70	9.80	9.80	9.80	9.80	9.80	9.80	9.80	9.80	9.80	9.80	9.80
					kgfcm	4.9	7.3	8.7	12.2	14.6	18.2	21.9	24.3	30.4	36.5	43.7	43.8	54.8	65.7	78.8	87.6	99.0	100.0	100.0	100.0	100.0	100.0	100.0	100.0	100.0	100.0	100.0	100.0
		N.m	0.48	0.71	0.86	1.19	1.43	1.79	2.14	2.38	2.98	3.57	4.29	4.29	5.37	6.44	7.73	8.58	9.70	9.80	9.80	9.80	9.80	9.80	9.80	9.80	9.80	9.80	9.80	9.80	9.80	9.80	
		90	220/240	50	kgfcm	4.2	6.3	7.6	10.5	12.6	15.8	19.0	21.1	26.3	31.6	37.9	38.0	47.5	56.9	68.3	75.9	85.8	100.0	100.0	100.0	100.0	100.0	100.0	100.0	100.0	100.0	100.0	100.0
					N.m	0.41	0.62	0.74	1.03	1.24	1.55	1.86	2.06	2.58	3.10	3.71	3.72	4.65	5.58	6.70	7.44	8.41	9.80	9.80	9.80	9.80	9.80	9.80	9.80	9.80	9.80	9.80	9.80
	kgfcm				1.4	2.1	2.5	3.4	4.1	5.2	6.2	6.9	8.6	10.3	12.4	12.4	15.5	18.6	22.3	24.8	28.1	33.7	42.1	50.5	56.1	67.3	84.2	100.0	100.0	100.0	100.0	100.0	100.0
	N.m	0.13	0.20	0.24	0.34	0.40	0.51	0.61	0.67	0.84	1.01	1.21	1.22	1.52	1.82	2.19	2.43	2.75	3.30	4.12	4.95	5.50	6.60	8.25	9.80	9.80	9.80	9.80	9.80	9.80			
	90	220/240	50	kgfcm	1.4	2.1	2.5	3.4	4.1	5.2	6.2	6.9	8.6	10.3	12.4	12.4	15.5	18.6	22.3	24.8	28.1	33.7	42.1	50.5	56.1	67.3	84.2	100.0	100.0	100.0	100.0	100.0	
				N.m	0.13	0.20	0.24	0.34	0.40	0.51	0.61	0.67	0.84	1.01	1.21	1.22	1.52	1.82	2.19	2.43	2.75	3.30	4.12	4.95	5.50	6.60	8.25	9.80	9.80	9.80	9.80	9.80	
				kgfcm	1.3	1.9	2.3	3.2	3.9	4.9	5.8	6.5	8.1	9.7	11.7	11.7	14.6	17.5	21.0	23.4	26.4	31.7	39.6	47.5	52.8	63.4	79.2	95.0	100.0	100.0	100.0	100.0	100.0
	N.m	0.13	0.19	0.23	0.32	0.38	0.48	0.57	0.64	0.79	0.95	1.14	1.14	1.43	1.72	2.06	2.29	2.59	3.10	3.88	4.66	5.17	6.21	7.76	9.31	9.80	9.80	9.80	9.80	9.80			

Motor Model	Gearbox Model	회전 속도 r/min	전압 V	주파수 Hz	감속비	10	12	15	18	25	30	36	50	60
9SRDG*-40W	9WD □BL / □BR / □BRL	1200	110	60	kgfcm	24.6	28.8	34.7	40.0	52.5	59.4	69.1	90.0	99.0
					N.m	2.41	2.82	3.40	3.92	5.15	5.82	6.77	8.82	9.70
					kgfcm	24.9	29.9	37.4	44.8	62.3	74.7	89.6	124.5	122.4
		N.m	2.44	2.93	3.66	4.39	6.10	7.32	8.78	12.20	12.00			
		90	220/240	50	kgfcm	26.2	30.7	37.0	42.6	56.0	63.4	73.7	96.0	105.6
					N.m	2.57	3.01	3.62	4.18	5.49	6.21	7.23	9.41	10.35
	kgfcm				7.0	8.2	9.8	11.3	14.9	16.8	19.6	25.5	28.1	
	N.m	0.68	0.80	0.96	1.11	1.46	1.65	1.92	2.50	2.75				
	90	220/240	50	kgfcm	7.0	8.2	9.8	11.3	14.9	16.8	19.6	25.5	28.1	
N.m				0.68	0.80	0.96	1.11	1.46	1.65	1.92	2.50	2.75		
kgfcm				7.4	8.6	10.4	12.0	15.8	17.8	20.7	27.0	29.7		
N.m	0.72	0.85	1.02	1.17	1.54	1.75	2.03	2.65	2.91					

- 1) 모터 모델명 □ 안에는 전압코드가 들어갑니다.
- 2) 감속기 모델명 □ 안에는 감속비가 들어갑니다.
- 3) 위의 표에서 색깔된 범위의 감속비를 선택했을 때 감속기의 출력축은 모터의 출력축과 같은 방향으로 회전합니다. 흰색 바탕 범위의 감속비에서는 감속기 출력축은 모터 출력축의 회전방향과 반대방향으로 회전합니다.
- 4) 회전속도(r/min)는 모터의 동기회전속도(50Hz:1500r/min, 60Hz:1800r/min)를 감속비로 나누어 계산합니다. 실제 회전속도는 부하의 크기에 따라 표시보다 2~20% 정도 느립니다.

Motor Model	Gearbox Model	회전속도 r/min	전압 V	주파수 Hz	감속비	2	3	3.6	5	6	7.5	9	10	12.5	15	18	20	25	30
9SRDG* -40P	9PBK□BH 9PFK□BH	1200	110	60	kgfcm	4.9	7.3	8.7	12.2	14.6	18.2	21.9	24.3	27.4	32.9	39.4	43.8	49.5	59.4
					N.m	0.48	0.71	0.86	1.19	1.43	1.79	2.14	2.38	2.68	3.22	3.86	4.29	4.85	5.82
					kgfcm	4.9	7.3	8.7	12.2	14.6	18.2	21.9	24.3	27.4	32.9	39.4	43.8	49.5	59.4
		N.m	0.48	0.71	0.86	1.19	1.43	1.79	2.14	2.38	2.68	3.22	3.86	4.29	4.85	5.82			
		kgfcm	4.2	6.3	7.6	10.5	12.6	15.8	19.0	21.1	23.7	28.5	34.2	38.0	42.9	51.5			
		N.m	0.41	0.62	0.74	1.03	1.24	1.55	1.86	2.06	2.33	2.79	3.35	3.72	4.20	5.05			
9SRDG* -40P	9PBK□BH 9PFK□BH	90	110	60	kgfcm	1.4	2.1	2.5	3.4	4.1	5.2	6.2	6.9	7.8	9.3	11.2	12.4	14.0	16.8
					N.m	0.13	0.20	0.24	0.34	0.40	0.51	0.61	0.67	0.76	0.91	1.09	1.22	1.37	1.65
					kgfcm	1.4	2.1	2.5	3.4	4.1	5.2	6.2	6.9	7.8	9.3	11.2	12.4	14.0	16.8
		N.m	0.13	0.20	0.24	0.34	0.40	0.51	0.61	0.67	0.76	0.91	1.09	1.22	1.37	1.65			
		kgfcm	1.3	1.9	2.3	3.2	3.9	4.9	5.8	6.5	7.3	8.8	10.5	11.7	13.2	15.8			
		N.m	0.13	0.19	0.23	0.32	0.38	0.48	0.57	0.64	0.72	0.86	1.03	1.14	1.29	1.55			

Motor Model	Gearbox Model	회전속도 r/min	전압 V	주파수 Hz	감속비	36	40	50	60	75	90	100	120	150	180	200
9SRDG* -40P	9PBK□BH 9PFK□BH	1200	110	60	kgfcm	71.3	79.2	99.0	118.8	132.8	159.3	177.0	200.0	200.0	200.0	200.0
					N.m	6.99	7.76	9.70	11.64	13.01	15.61	17.35	19.60	19.60	19.60	19.60
					kgfcm	71.3	79.2	99.0	118.8	132.8	159.3	177.0	200.0	200.0	200.0	200.0
		N.m	6.99	7.76	9.70	11.64	13.01	15.61	17.35	19.60	19.60	19.60	19.60			
		kgfcm	61.8	68.6	85.8	103.0	115.1	138.1	153.4	184.1	200.0	200.0	200.0			
		N.m	6.05	6.73	8.41	10.09	11.27	13.53	15.03	18.04	19.60	19.60	19.60			
9SRDG* -40P	9PBK□BH 9PFK□BH	90	110	60	kgfcm	20.2	22.4	28.1	33.7	37.6	45.1	50.2	60.2	75.2	90.3	100.3
					N.m	1.98	2.20	2.75	3.30	3.69	4.42	4.91	5.90	7.37	8.85	9.83
					kgfcm	20.2	22.4	28.1	33.7	37.6	45.1	50.2	60.2	75.2	90.3	100.3
		N.m	1.98	2.20	2.75	3.30	3.69	4.42	4.91	5.90	7.37	8.85	9.83			
		kgfcm	19.0	21.1	26.4	31.7	35.4	42.5	47.2	56.6	70.8	85.0	94.4			
		N.m	1.86	2.07	2.59	3.10	3.47	4.16	4.63	5.55	6.94	8.33	9.25			

Dimensions

MOTOR ONLY

- MOTOR MODEL: 9SRDD□-40 (NO FAN)

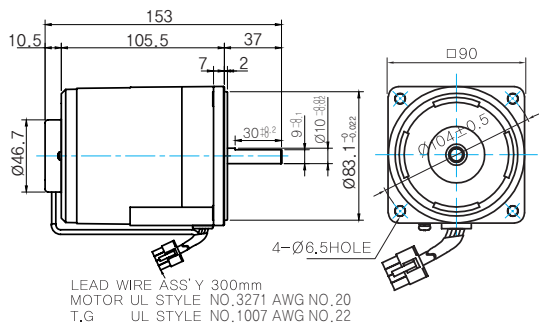

MOTOR OUTPUT SHAFT

MODEL	SPEC
D-CUT TYPE	
9SRDD□-40	
KEY TYPE	
9SRDK□-40	

KEY SPEC

GEARBOX

중간감속기

- MODEL: 9XD10□□

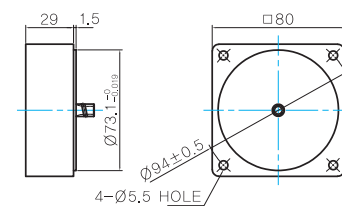

GEARED MOTOR

G TYPE GEARBOX

- MOTOR MODEL: 9SRDG□-40G (NO FAN)
- GEARBOX MODEL: 9GBK□BMH

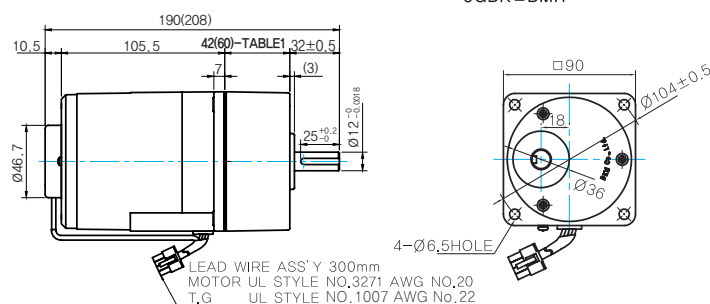

GEARBOX OUTPUT SHAFT

MODEL	SPEC
KEY TYPE	

KEY SPEC

GEARBOX

42(60)-Table1

SIZE(mm)	GEAR RATIO
42	9GBK2BMH - 9GBK18BMH
60	9GBK20BMH - 9GBK200BMH

B AC Motors

S.C. Reversible Motor 40W (□90mm)

P TYPE GEARBOX

MOTOR MODEL:
9SRDG□-40G (NO FAN)

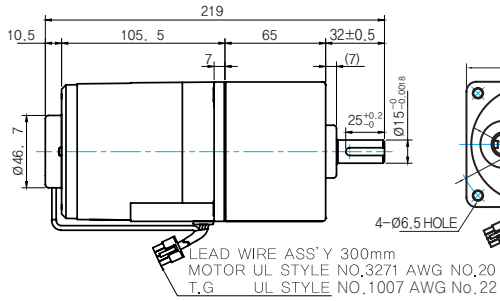

GEARBOX MODEL:
9PBK□BH

GEARBOX MODEL:
9PFK□BH

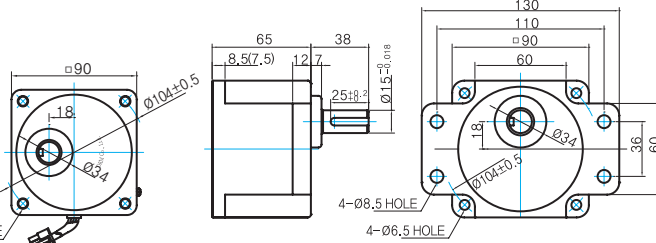

GEARBOX OUTPUT SHAFT

MODEL	SPEC
KEY TYPE	
9PBK□BH	
9PFK□BH	

KEY SPEC

GEARBOX

W TYPE GEARBOX

MOTOR MODEL:
9SRDG□-40W (NO FAN)

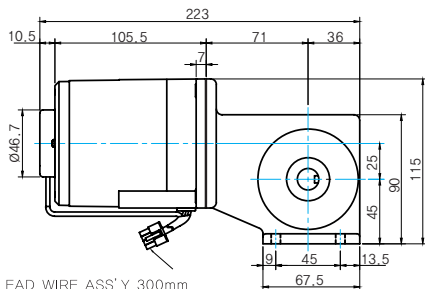

GEARBOX MODEL:
9WD□BL/BR/BRL

KEY SPEC

GEARBOX

WEIGHT

PART	WEIGHT(Kg)	
MOTOR	2.55	
GEAR BOX	9GBK2BMH ~ 9GBK18BMH	0.78
	9GBK20BMH ~ 9GBK40BMH	1.1
	9GBK50BMH ~ 9GBK200BMH	1.2
	9PB(F)K2BH ~ 9PB(F)K10BH	1.28
	9PB(F)K12.5BH ~ 9PB(F)K20BH	1.3
	9PB(F)K25BH ~ 9PB(F)K60BH	1.45
	9PB(F)K75BH ~ 9PB(F)K200BH	1.47
	9WD□BL/BR/BRL	1.0
	9XD10□	0.6

Motor Images

